

## Mini Review Paper

# Applications of DSTATCOM Using MATLAB/Simulation in Power System

**Bhattacharya Sourabh**  
NIIIST Bhopal, MP, INDIA

Available online at: [www.isca.in](http://www.isca.in)

(Received 17<sup>th</sup> October 2011, revised 7<sup>th</sup> January 2012, accepted 25<sup>th</sup> January 2012)

## Abstract

*D-STATCOM (Distribution Static Compensator) is a shunt device which is generally used to solve power quality problems in distribution systems. D-STATCOM is a shunt device used in correcting power factor, maintaining constant distribution voltage and mitigating harmonics in a distribution network. D-STATCOM is used for Grid Connected Power System, for Voltage Fluctuation, for Wind Power Smoothing and Hydrogen Generation etc. This paper D-STATCOM is used in Marine Power System for Power Quality Improvement. Relevant solutions which applied nowadays to improve power quality of electric network according to the five aspects of power quality- harmonics, fluctuation and flick of voltage, Voltage deviation, unbalance of 3-phase voltage and current frequency deviation. Simulation is done using Sim Power Systems of MATLAB/Simulink to validate the proposed global system. The measurement system containing two main parts: - Hardware part and the virtual part- software (Recording, Processing, Graphical interfacing). In this paper we are concluding the result of software parts only. The performance of the proposed DSTATCOM system is validated through simulations using MATLAB software with its Simulink and Power System Blockset (PSB) toolboxes.*

**Keywords:** D-STATCOM, VSI, PCC, SOLAS, GMDSS, PSB, APF.

## Introduction

In order to improve the survivability of a navy ship in battle condition, DSTATCOM or Distribution Static Compensator can be used, which reduces the impact of pulsed loads on the bus voltage and thus keeps the bus voltage at desired level. DSTATCOM is a voltage-source inverter (VSI) based shunt device generally used in distribution system to improve power quality. The main advantage of DSTATCOM is that, it has a very sophisticated power electronics based control which can efficiently regulate the current injection into the distribution bus. The second advantage is that, it has multifarious applications, e.g. i. cancelling the effect of poor load power factor, ii. suppressing the effect of harmonic content in load currents, iii. regulating the voltage of distribution bus against sag/swell etc., compensating the reactive power requirement of the load and so on. The performance of the DSTATCOM is very much dependent on the DSTATCOM controller.

**Basic principle of DSTATCOM:** A DSTATCOM is a controlled reactive source, which includes a Voltage Source Converter (VSC) and a DC link capacitor connected in shunt, capable of generating and/or absorbing reactive power. The operating principles of a DSTATCOM are based on the exact equivalence of the conventional rotating synchronous compensator.

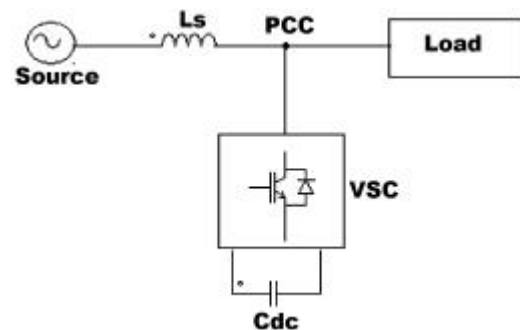

**Figure-1**  
**Basic structure of DSTATCOM**

The AC terminals of the VSC are connected to the Point of Common Coupling (PCC) through an inductance, which could be a filter inductance or the leakage inductance of the coupling transformer, as shown in figure 1. The DC side of the converter is connected to a DC capacitor, which carries the input ripple current of the converter and is the main reactive energy storage element. This capacitor could be charged by a battery source, or could be recharged by the converter itself. If the output voltage of the VSC is equal to the AC terminal voltage, no reactive power is delivered to the system. If the output voltage is greater than the AC terminal voltage, the DSTATCOM is in the capacitive mode of operation and vice versa. The quantity of reactive power flow is proportional to the difference in the two voltages. It is

to be noted that voltage regulation at PCC and power factor correction cannot be achieved simultaneously. For a DSTATCOM used for voltage regulation at the PCC, the compensation should be such that the supply currents should lead the supply voltages; whereas, for power factor Correction, the supply current should be in phase with the supply voltages. The control strategies studied in this paper are applied with a view to study-ing the performance of a DSTATCOM for power factor correction and harmonic mitigation.

**Basic Configuration and Operation of D-STATCOM:**

The D-STATCOM is a three-phase and shunt connected power electronics based device. It is connected near the load at the distribution systems. The major components of a D-STATCOM are shown in figure 2. It consists of a dc capacitor, three-phase inverter (IGBT, thyristor) module, ac filter, coupling transformer and a control strategy. The basic electronic block of the D-STATCOM is the voltage-sourced inverter that converts an input dc voltage into a three-phase output voltage at fundamental frequency.

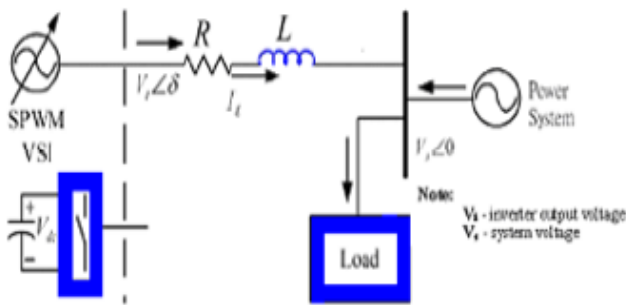

**Figure-2**  
**Basic Building Blocks of the D-STATCOM**

The D-STACOM employs an inverter to convert the DC link voltage  $V_{dc}$  on the capacitor to a voltage source of adjustable magnitude and phase. Therefore the D-STATCOM can be treated as a voltage-controlled source. The D-STATCOM can also be seen as a current-controlled source.

Figure 2 shows the inductance  $L$  and resistance  $R$  which represent the equivalent circuit elements of the stepdown transformer and the inverter will be the main component of the D-STATCOM. The voltage  $V_i$  is the effective output voltage of the D-STATCOM and  $\delta$  is the power angle. The reactive power output of the D-STATCOM inductive or capacitive depending can be either on the operation mode of the DSTATCOM. The construction controller of the D-STATCOM is used to operate the inverter in such a way that the phase angle between the inverter voltage and the line voltage is dynamically adjusted so that the D-STATCOM generates or absorbs the desired VAR at the point of connection. The phase of the output voltage of the thyristor-based inverter,  $V_i$ , is controlled in the same way as the distribution system voltage,  $V_s$ .

The situation of marine power quality inclined to worse. The reasons are listed in the following: i. A large amount of control equipments and power electronic devices are put into marine use in order to promote automatization of ship operation and to save energy. e.g., concerning the variation of main engine cooling water temperature, the conventional control method of regulation of valve baffle position is now substituted by speed regulation of motors of cooling water pumps in order to save energy. As well as more and more frequent application of shaft driven generator has been observed. But the operation of all these equipments and devices contributes to the power quality deterioration to a wide extension. ii. Since the capacity of marine electric facilities is always with a plentiful margin, the power factor of marine power plant under normal operation is rather low.

**Operation modes of D-STATCOM**

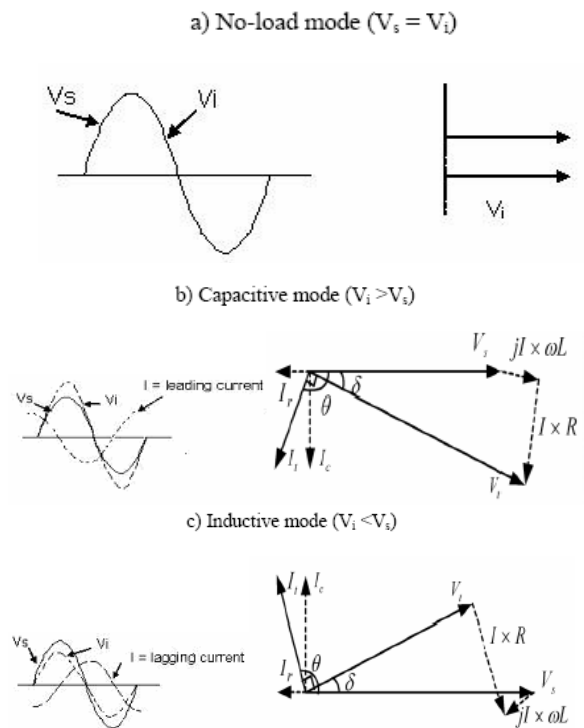

**Figure-3**  
**Basic Building Blocks of the D-STATCOM**

**Commonly Used Solutions to Improve Electric Power Quality:**

i. There are three ways that is commonly applied to improve voltage deviation of electrical power system. The most effective solution is reactive power compensation, as SVC - Static Var Compensator (typically, TCR-Thyristor Controlled Reactors and TSC-Thyristor Switched Capacitors), SVG - Static Var Generator and APFCC-Active Power Factor Correction Circuit. Other solutions include regulation of field current of synchomotor, application of on-load voltage regulation transformer. ii. A large number of

solutions have been selected to solve the problem of fluctuation and flick of voltage and almost all these solutions simultaneously have the function of harmonic suppression. iii. To suppress harmonics in electrical power quality. The most effective solution is to apply filters. The commonly applied filters are passive power filter (usually passive LC filter) and active power filter (APF). APF normally has two types according to the ways it connects to the object that is compensated shunt APF and series APF. Among which, shunt APF is common in practical application.

**Power Quality Improvement in Ship Networks:** Marine electrical power network demands even higher quality of electrical power energy while compared with overland power network. Requirements that should be met during the process of measurement for electrical power quality assessment are: i. be able to catch instantaneous interference very quickly, e.g. variation of amplitude, distortion of waveform and rate of enlargement of amplitude. ii. quick and accurate measurement for harmonics and inter harmonics. iii. be able to reveal the characteristics and regulations of the electrical power quality indices as well as regulations of the variation along with variation of time using an effective analysis and automatic identification system.

**Voltage Source Convertors (VSC):** A voltage-source converter is a power electronic device, which can generate a sinusoidal voltage with any required magnitude, frequency and phase angle. Voltage source converters are widely used in adjustable-speed drives, but can also be used to mitigate voltage dips. The VSC is used to either completely replace the voltage or to inject the 'missing voltage'. The 'missing voltage' is the difference between the nominal voltage and the actual. The converter is normally based on some kind of energy storage, which will supply the converter with a DC voltage. The solid-state electronics in the converter is then switched to get the desired output voltage. Normally the VSC is not only used for voltage dip mitigation, but also for other power quality issues, e.g. flicker and harmonic.

**Commonly applied solutions to improve marine electrical power quality: Division of the ship power system:** One of the recommendations of the SOLAS convention concerns an appropriate configuration of the main switchboard. Regarding this recommendation for a ship power station with a high power, the main switch board should be divided into sections. Then, the loads with increased sensitivity for changes of voltage supply parameters (for example GMDSS systems) and devices with special significance for ship safety may be supplied from the separated sub-system. Specialized constructional and technological solutions are employed, e.g. to employ 12-phase (or 24-phase) frequency transformer and low reactance generators, as well as special earthing to drain the frequencies induced in protective shields. To install filters and power factor correction circuits for quick and

accurate suppression of dominant harmonics and reactive power compensation.

**MATLAB Based Test System:** The ship power system actually consists of four generators and two propulsion motors. But, to study the effect of DSTATCOM, a simplified model consisting of one generator of 36 MW/45 MVA and a propulsion motor of 20 MW is considered in this paper. The model of the test system is built in MATLAB/SIMULINK environment.

## Conclusion

This paper has presented the application of DSTATCOM to improve the power quality in a ship power system during and after pulsed loads. The expected simulation results show that the voltage regulation at the point of common coupling is much better with a DSTATCOM.

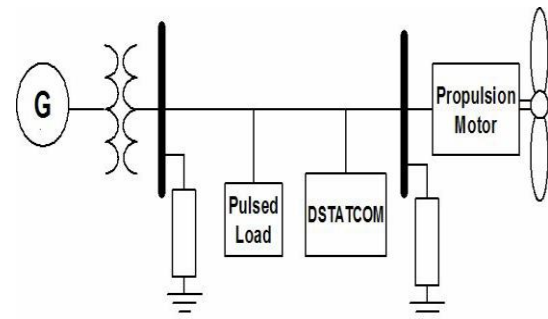

Figure-4  
Test Ship Power System

## References

1. Xiaoyan Xu, Min He and Huayao Zheng, Study of Electric Power Quality Improvement in Ship Networks, *Industrial Electronics and Applications*, 2006 1ST IEEE Conference, 1-6, (2006)
2. Gupta R. and Ghosh A., Frequency-Domain Characterization of Sliding Mode Control of an Inverter Used in DSTATCOM Application, *IEEE Transactions on Circuits and Systems—I: Regular Papers*, 53(3), 662-676 (2006)
3. Sundar G., et.al., Digital Simulation of D-STATCOM for Voltage Fluctuation, *International Journal of Engineering Science and Technology*, 2(5), 1131-1135 (2010)
4. Improvement of Power Quality in Electric ship power system Using Controller of D-statcom, *International Journal of Engineering Trends and Technology*, 2(2) (2011)
5. Wasiak I., Mienski R., Pawelek R. and Gburczyk P., Application of DSTATCOM compensators for

- mitigation of power quality disturbances in low voltage grid with distributed generation Electrical Power Quality and Utilisation, *IEEE 9<sup>th</sup> International Conference on Digital Object Identifier*, 1-6 (2007)
6. Karanki S.B., Nagesh G., Mishra M.K. and Kumar B.K., A hybrid topology for reducing DC link voltage rating in DSTATCOM applications *Energytech, 2011 IEEE Digital Object Identifier: 10.1109/Energy Tech. 2011, 5948517*, 1–6 (2011)
  7. Singh B., Adya A., Mittal A.P., Gupta J.R.P. and Singh B.N., Application of DSTATCOM for Mitigation of Voltage Sag for Motor Loads in Isolated Distribution Systems *Industrial Electronics, 2006 IEEE International Symposium on Digital Object Identifier*, 10.1109/ISIE.2006.295846, **3**, 1806 - 1811 (2006)
  8. Singh A. and Singh B., Performance evaluation of power converters with distribution static compensator, *Power Electronics, Drives and Energy Systems (PEDES) and 2010 Power India, 2010 Joint International Conference on Digital Object Identifier*, 1109/PEDES.2010.5712484, **10**, 1-5 (2010)
  9. Anuradha K., Muni B.P. and Kumar A.D.R., Control of Cascaded H-Bridge Converter based DSTATCOM for High Power Applications Power Electronics, Drives and Energy Systems, 2006, *PEDES '06. International Conference on Digital Object Identifier*, 1109/PEDES.2006.344257, **10**, 1-6 (2006)
  10. Karanki S.B., Nagesh G., Mishra M.K. and Kumar B.K., A hybrid topology for reducing DC link voltage rating in DSTATCOM applications *Energytech, 2011 IEEE Digital Object Identifier: 10.1109/EnergyTech. 2011. 5948517*, 1-6 (2011)